



Model Number

NJ40-FP-SN-P1

Features

- 40 mm non-flush
- Usable up to SIL 3 acc. to IEC 61508

Application



Danger!

In safety-related applications the sensor must be operated with a qualified fail safe interface from Pepperl+Fuchs, such as KFD2-SH-EX1. Consider the "exida Functional Safety Assessment" document which is available on as an integral part entation.

Technical Data

General specifications

Switching function	Normally closed (NC)
Output type	NAMUR with safety function
Rated operating distance	s_n 40 mm
Installation	non-flush
Assured operating distance	s_a 0 ... 32.4 mm
Reduction factor r_{AI}	0.4
Reduction factor r_{Cu}	0.3
Reduction factor r_{304}	0.85
Safety Integrity Level (SIL)	up to SIL3 acc. to IEC 61508 Danger! In safety-related applications the sensor must be operated with a qualified fail safe interface from Pepperl+Fuchs, such as KFD2-SH-EX1. Consider the "exida Functional Safety Assessment" document which is available on this product's document as an integral part of this product's document
Output type	2-wire

Nominal ratings

Nominal voltage	U_o 8.2 V (R_i approx. 1 k Ω)
Switching frequency	f 0 ... 100 Hz
Current consumption	
Measuring plate not detected	≥ 3 mA
Measuring plate detected	≤ 1 mA

Functional safety related parameters

Safety Integrity Level (SIL)	SIL 3
MTTF _d	7560 a
Mission Time (T _M)	20 a
Diagnostic Coverage (DC)	0 %

Ambient conditions

Ambient temperature	-40 ... 100 °C (-40 ... 212 °F)
---------------------	---------------------------------

Mechanical specifications

Connection type	screw terminals
Core cross-section	up to 2.5 mm ²
Housing material	PBT
Sensing face	PBT
Degree of protection	IP68

General information

Use in the hazardous area	see instruction manuals
---------------------------	-------------------------

Compliance with standards and directives

Standard conformity	
NAMUR	EN 60947-5-6:2000 IEC 60947-5-6:1999
Standards	EN 60947-5-2:2007 EN 60947-5-2/A1:2012 IEC 60947-5-2:2007 IEC 60947-5-2 AMD 1:2012

Approvals and certificates

EAC conformity	TR CU 012/2011
UL approval	cULus Listed, General Purpose
CSA approval	cCSAus Listed, General Purpose
CCC approval	CCC approval / marking not required for products rated ≤ 36 V

Dimensions

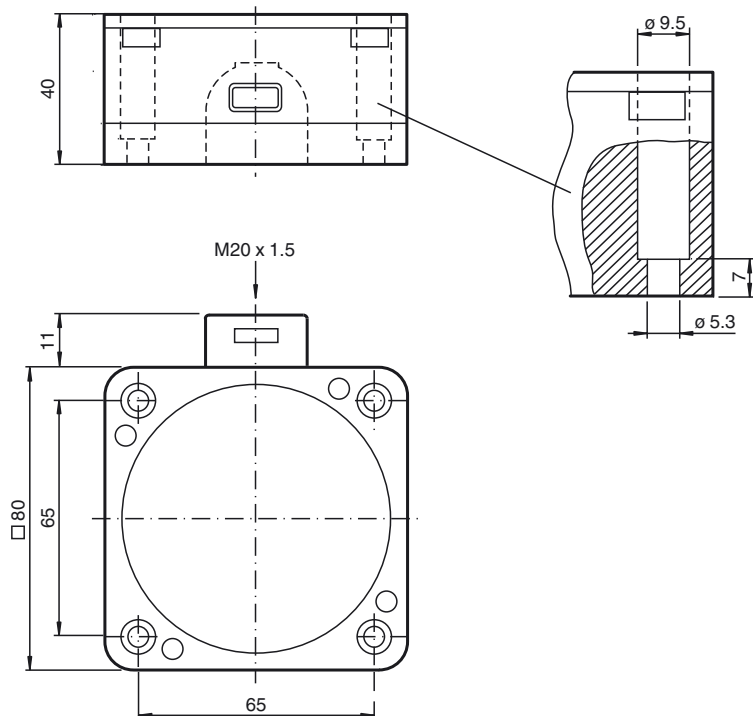

Release date: 2018-04-19 08:20 Date of issue: 2018-04-19 106696_eng.xml

Electrical Connection

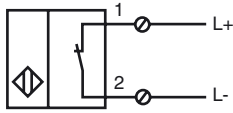

Data for application in connection with hazardous areas

Equipment protection level	Gb , Da , Mb
----------------------------	--------------

Equipment protection level Gb

Type of protection	intrinsic safety
CE marking	CE 0102

Certificates

Appropriate type	NJ 40-FP-SN...
ATEX certificate	PTB 00 ATEX 2049 X
ATEX marking	Ⓔ II 2G Ex ia IIC T6...T1 Gb
Standards	EN 60079-0:2012+A11:2013 , EN 60079-11:2012
IECEX certificate	IECEX PTB 11.0092X
IECEX marking	Ex ia IIC T6...T1 Gb
Standards	IEC 60079-0:2011 , IEC 60079-11:2011

Effective internal inductivity	C_i	≤ 370 nF A cable length of 10 m is considered.
--------------------------------	-------	--

Effective internal inductance	L_i	≤ 300 μ H A cable length of 10 m is considered.
-------------------------------	-------	---

Maximum permissible ambient temperature T_{amb}	Also observe the maximum permissible ambient temperature stated in the general technical data. Keep to the lower of the two values. at $U_i = 16$ V , $I_i = 25$ mA , $P_i = 34$ mW , T6 : 73 °C (163.4 °F) T5 : 88 °C (190.4 °F) T4 : 100 °C (212 °F) T3 : 100 °C (212 °F) T2 : 100 °C (212 °F) T1 : 100 °C (212 °F) at $U_i = 16$ V , $I_i = 25$ mA , $P_i = 64$ mW , T6 : 66 °C (150.8 °F) T5 : 81 °C (177.8 °F) T4 : 100 °C (212 °F) T3 : 100 °C (212 °F) T2 : 100 °C (212 °F) T1 : 100 °C (212 °F) at $U_i = 16$ V , $I_i = 52$ mA , $P_i = 169$ mW , T6 : 45 °C (113 °F) T5 : 60 °C (140 °F) T4 : 89 °C (192.2 °F) T3 : 89 °C (192.2 °F) T2 : 89 °C (192.2 °F) T1 : 89 °C (192.2 °F) at $U_i = 16$ V , $I_i = 76$ mA , $P_i = 242$ mW , T6 : 30 °C (86 °F) T5 : 45 °C (113 °F) T4 : 74 °C (165.2 °F) T3 : 74 °C (165.2 °F) T2 : 74 °C (165.2 °F) T1 : 74 °C (165.2 °F)
---	--

Equipment protection level Da

Type of protection	intrinsic safety
CE marking	CE 0102

Certificates

Appropriate type	NJ 40-FP-SN...
ATEX certificate	PTB 00 ATEX 2049 X
ATEX marking	Ⓔ II 1D Ex ia IIIC T135°C Da
Standards	EN 60079-0:2012+A11:2013 , EN 60079-11:2012
IECEX certificate	IECEX PTB 11.0092X
IECEX marking	Ex ia IIIC T135°C Da
Standards	IEC 60079-0:2011 , IEC 60079-11:2011

Effective internal inductivity	C_i	≤ 370 nF A cable length of 10 m is considered.
--------------------------------	-------	--

Effective internal inductance	L_i	≤ 300 μ H A cable length of 10 m is considered.
-------------------------------	-------	---

Maximum permissible ambient temperature T_{amb}	Also observe the maximum permissible ambient temperature stated in the general technical data. Keep to the lower of the two values. at $U_i = 16$ V , $I_i = 25$ mA , $P_i = 34$ mW : 100 °C (212 °F) at $U_i = 16$ V , $I_i = 25$ mA , $P_i = 64$ mW : 100 °C (212 °F) at $U_i = 16$ V , $I_i = 52$ mA , $P_i = 169$ mW : 89 °C (192.2 °F) at $U_i = 16$ V , $I_i = 76$ mA , $P_i = 242$ mW : 74 °C (165.2 °F)
---	---

Equipment protection level Mb

Type of protection	intrinsic safety
--------------------	------------------

Certificates

Appropriate type	NJ 40-FP-SN...
IECEX certificate	IECEX PTB 11.0092X
IECEX marking	Ex ia I Mb
Standards	IEC 60079-0:2011 , IEC 60079-11:2011

Effective internal inductivity	C_i	≤ 370 nF A cable length of 10 m is considered.
--------------------------------	-------	--

Effective internal inductance	L_i	≤ 300 μ H A cable length of 10 m is considered.
-------------------------------	-------	---

Maximum permissible ambient temperature T_{amb}

Also observe the maximum permissible ambient temperature stated in the general technical data.

Keep to the lower of the two values.

at $U_i = 16\text{ V}$, $I_i = 25\text{ mA}$, $P_i = 34\text{ mW}$: 100 °C (212 °F)

at $U_i = 16\text{ V}$, $I_i = 25\text{ mA}$, $P_i = 64\text{ mW}$: 100 °C (212 °F)

at $U_i = 16\text{ V}$, $I_i = 52\text{ mA}$, $P_i = 169\text{ mW}$: 89 °C (192.2 °F)

at $U_i = 16\text{ V}$, $I_i = 76\text{ mA}$, $P_i = 242\text{ mW}$: 74 °C (165.2 °F)